

# Re-screening M3500

1

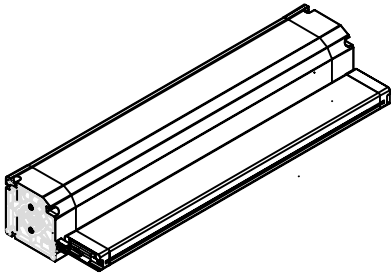

Remove the screen unit from the opening and place on a flat surface.

2

Remove the two screws holding the cassette cover in place and remove the cover.

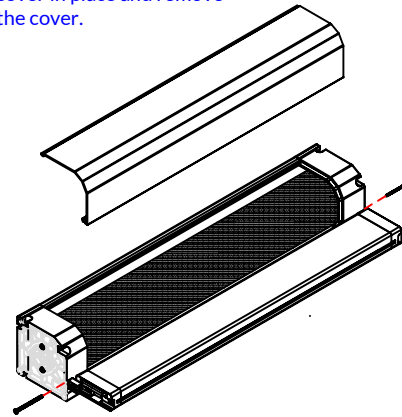

3

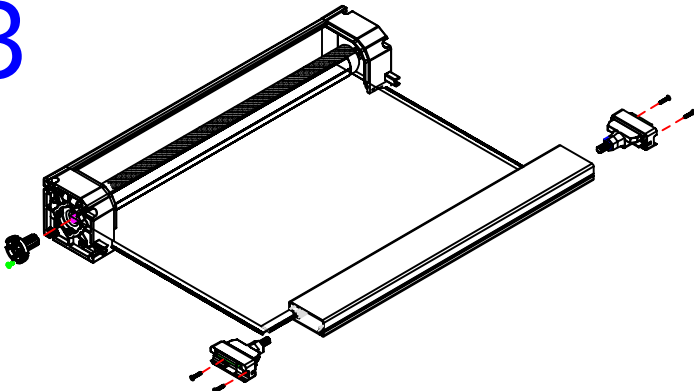

Remove the spring tensioner to release spring tension. Remove both draw bar guides and draw bar from the mesh.

4

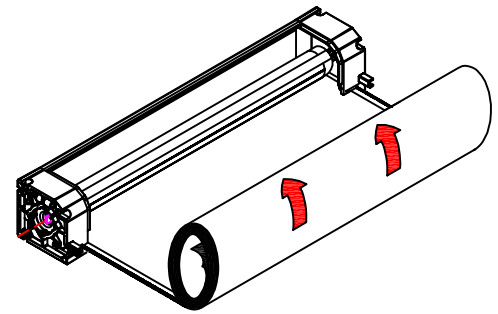

With the spring tension released, roll the mesh off the roller tube.

5

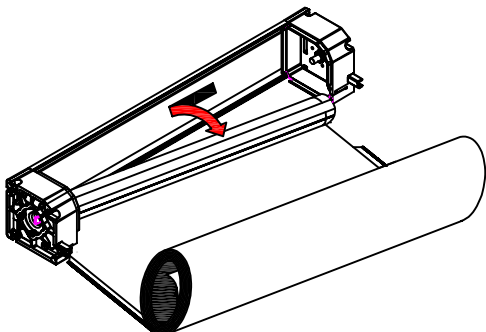

Remove the roller tube and mesh from the cassette.

6

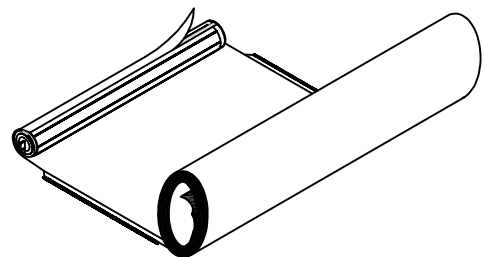

Detach the old mesh from the roller tube and discard.

# 7

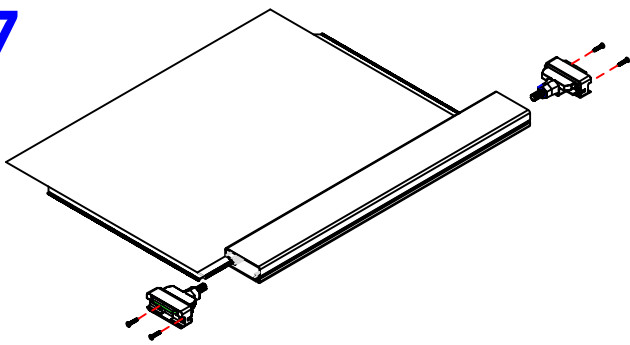

Attach the new mesh to the draw bar and reattach the draw bar guides.

# 8

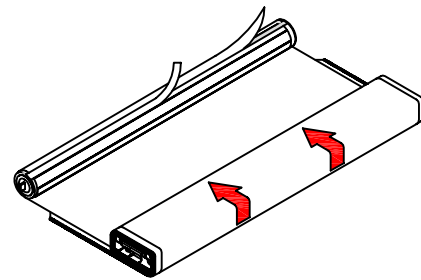

Wind the new mesh around the draw bar to make it more manageable and attach the free edge of the new mesh to the roller tube, using new double-sided and masking tape if needed.

# 9

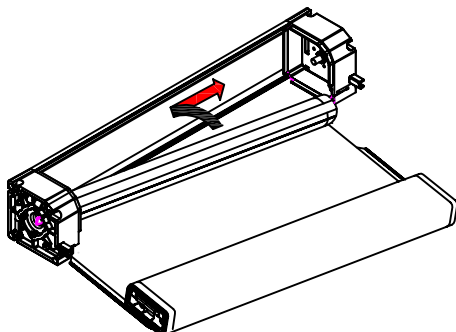

With the mesh still wound around the draw bar, insert the roller tube into the cassette.

# 10

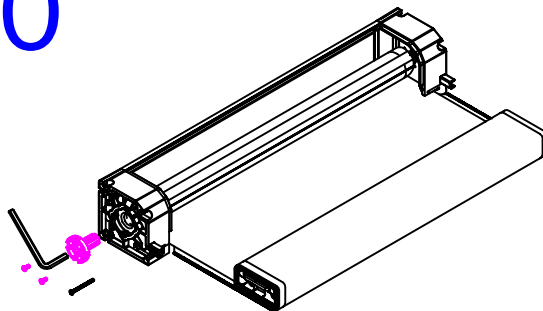

Insert the spring tensioner through the cassette cap and onto the spring head.

# 11

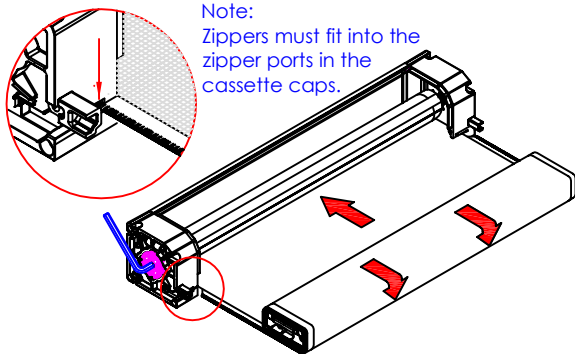

Using a 1/4" Allen wrench to tension the spring, allow the mesh to be wound onto the roller tube while gradually unwinding it off the draw bar.

# 12

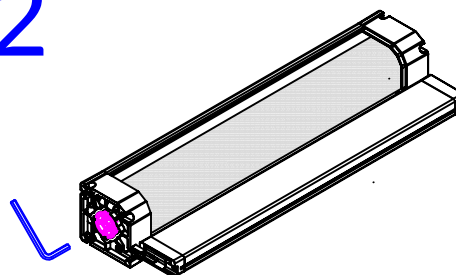

Once the mesh is fully wound onto the roller tube, release all spring tension.

# 13

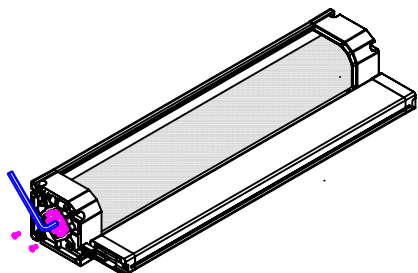

With the mesh fully wound onto the roller tube, tension the spring a full 19 turns and re-secure the spring tensioner with the two screws previously removed.

# 14

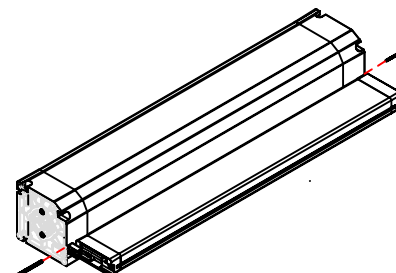

Attach the hood cover and secure with the two screws previously removed.